

MagSense®

User Manual

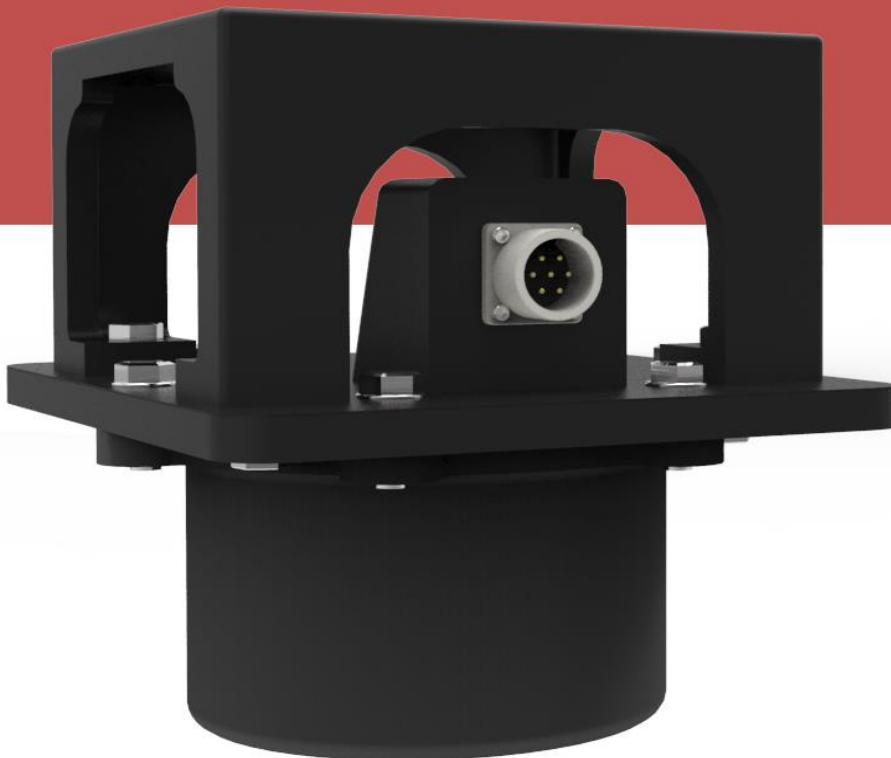

MagSense® User Manual

Copyright Notice

© 2025 MRD Rail Technologies Pty Ltd. All rights reserved.

Trademarks

The MRD logo is registered trademark of MRD Rail Technologies Pty Ltd.

All other trademarks or registered marks in this manual belong to their respective manufacturers.

Disclaimer

Information in this document is subject to change without notice and does not represent a commitment on the part of MRD Rail Technologies Pty Ltd.

MRD provides this document as is, without warranty of any kind, either expressed or implied, including, but not limited to, its particular purpose. MRD reserves the right to make improvements and/or changes to this manual, or to the products and/or the programs described in this manual, at any time.

Information provided in this manual is intended to be accurate and reliable. However, MRD assumes no responsibility for its use, or for any infringements on the rights of third parties that may result from its use.

This product might include unintentional technical or typographical errors. Changes are periodically made to the information herein to correct such errors, and these changes are incorporated into new edition of the publication.

Technical Support Contact Information

Tel: +61 7 3821 5151

Fax: +61 7 3821 5152

Email: support@mrd.com.au

Website: www.mrd.com.au

Version	Author	Approver	Date	Class
1.0	Leandro Iwanski		22/01/2014	Release
2.0	Liam Hoffman		08/01/2025	Release

Table of Contents

1. Introduction	1
2. Basic Operation	1
3. Package Checklist	1
4. Product Features	2
5. Reset Functionality	2
6. Dimensions	3
7. Pin Allocations	4
8. Operation Mode	5
9. Ordering Information	5
10. Technical Specifications	6

1. Introduction

The MagSense® is designed to accurately detect the sequence and polarities of magnetic fields emitted by the configurations of Automatic Warning System (AWS) track magnets. It features the latest integrated circuit technology in combination with a solid and robust enclosure to ensure high reliability and performance.

2. Basic Operation

The MagSense® is a magnet receiver which accurately measures the field strength of AWS track magnets and then sets its outputs according to the magnet polarity and a defined threshold. It provides a RESET pin to default the outputs after the magnet has been measured. The MagSense® default functionality is to hold the South output high and the North output low. If a North field is detected, then these outputs will reverse with North high and South low until a South field is detected, or the RESET pin is pulled high.

3. Package Checklist

The MagSense® is shipped with the following items. If any of these items are missing or damaged, please contact our sales representative for assistance.

- MagSense®
- Quick Installation Guide

4. Product Features

- Wide Input Voltage
- Gel Filled
- Robust design
- Maintenance limited to functional testing only
- Retrofit option available to use with the existing UG/Fischer enclosure
- No moving parts
- Easy installation

5. Reset Functionality

The MagSense® can also be supplied with a software feature which enables the MagSense® to automatically switch back to a South output when a North signal has been removed. MagSense® with this feature can be easily identified by the yellow-coloured bowl. The reset occurs 1.3 seconds after the North field has been removed

The below table outlines the possible states.

MagSense Reset Functionality		
STATE	OUTPUTS	
	South Output	North Output
Unit Powered (no field detected)	1	0
South Field Detected	1	0
North Field Detected	0	1
Reset (Automatically 1.3 seconds after North field removed)	1	0

6. Dimensions

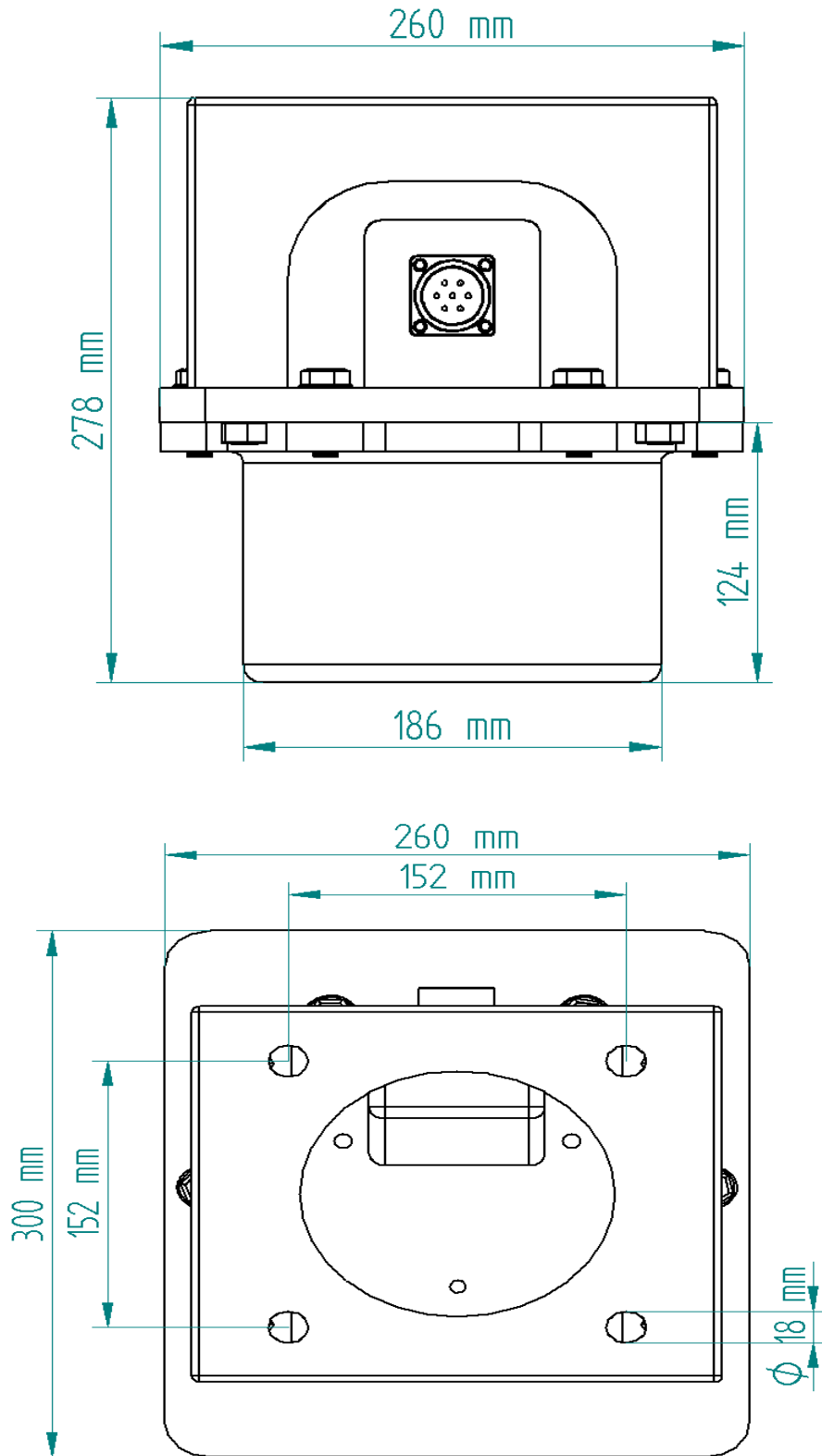

7. Pin Allocations

ITT Cannon CA-Bayonet Connector

PIN	Function
A	74VDC POS (PA)
B	NTH POLE OUT
C	STH POLE OUT
D	74VDC NEG (NA)
E	RESET
F	NC
G	NC

CA3102E20-15PBA176 Connector

Marechal Connector

PIN	Function
1	74VDC POS (PA)
2	NTH POLE OUT
3	STH POLE OUT
EARTH	RESET
N	74VDC NEG (NA)

01N4017 Connector

8. Operation Mode

The MagSense® can be configured to different operation modes depending on the application. The standard configuration is shown in the table below:

MD01 (Latching Outputs)				
INPUTS			OUTPUTS	
Reset	South Field	North Field	South Output	North Output
1	-	-	1	0
0	1	0	1	0
0	0	1	0	1

9. Ordering Information

Part Number			
Type	Connector	Mode	Description
MS	C	MD01	MagSense Cannon Connector MD01
	M		MagSense Marechal Connector MD01
MSR	C	MD01	MagSense Retrofit Cannon Connector MD01
	M		MagSense Retrofit Marechal Connector MD01
MagSense Upgrade			MagSense Reset Functionality Upgrade to any of the above units

10. Technical Specifications

Power	
Input	50 to 150VDC
Consumption	10W
Input	
Reset Impedance	90KΩ
Minimum Reset Voltage	45 to 150VDC
Output	
Voltage	Within 10% of the supply voltage
Maximum current	50mA
Sensitivity / Threshold	
North	22.5 ± 2.5 Gauss
South	17.5 ± 2.5 Gauss
Mechanical	
Casing	IP67 protection, metal case
Dimension (W x D x H)	230mm x 230mm x 279mm
Weight	Approximately 6Kg
Environmental	
Operating Temperature	-25 to 70°C (EN50155)
Storage Temperature	-40 to 85°C
Ambient Relative Humidity	5 to 95% (non-condensing)
Regulatory Approvals	
Transient & Surge Testing	EN50155 (pending)
Vibration & Shock	EN61373 (pending)
EMC	EN50121-3-2 (pending)
MTBF	On request
WARRANTY	3 years