

# Earth Leakage Detector®

ELD-AC/DC-AUTO-110

ELD-AC/DC-AUTO-12

## Installation and Operation Manual

V2.5



## **Earth Leakage Detector (ELD) User Manual**

The software described in this manual is furnished under a license agreement and may be used only in accordance with the terms of that agreement.

### **Copyright Notice**

© 2024 MRD Rail Technologies Pty Ltd. All rights reserved.

### **Trademarks**

The MRD logo is registered trademark of MRD Rail Technologies Pty Ltd.

All other trademarks or registered marks in this manual belong to their respective holders.

### **Disclaimer**

Information in this document is subject to change without notice and does not represent a commitment on the part of MRD Rail Technologies Pty Ltd.

MRD provides this document as is, without warranty of any kind, expressed or implied, including, but not limited to, its particular purpose. MRD reserves the right to make improvements and/or changes to this manual, or to the products and/or the programs described in this manual, at any time.

Information provided in this manual is intended to be accurate and reliable. However, MRD assumes no responsibility for its use, or for any infringements on the rights of third parties that may result from its use.

This manual, and the product it relates to, might include unintentional technical or typographical errors. Changes are periodically made to the information herein to correct such errors, and these changes are incorporated into new edition of the publication.

### **Technical Support Contact Information**

Tel: +61 7 3821 5151

Fax: +61 7 3821 5152

Email: [support@mrd.com.au](mailto:support@mrd.com.au)

<b>Version</b>	<b>Author</b>	<b>Approver</b>	<b>Date</b>	<b>Class</b>
1.0	Rob Gersbach		15/03/2013	Draft
1.1	Leandro Iwanski		30/09/2013	
2.0	Callum Gersbach		15/10/2013	
2.1	Liam Hoffman		24/04/2020	
2.2	Liam Hoffman		02/05/2024	
2.3	Liam Hoffman		26/06/2024	
2.4	Liam Hoffman		25/10/2024	
2.5	Liam Hoffman		26/11/2024	Release

# Table of Contents

## Contents

Table of Contents .....	4
1. Introduction .....	1
2. General Description .....	1
3. Product Features .....	1
4. Wiring Diagram.....	2
5. Connectors .....	5
6. Installation .....	6
7. Q-Style Panel Mount Bracket .....	7
8. Functions.....	8
9. Operation Instructions for Monitoring AC Busbars .....	9
10. Operation Instructions for monitoring DC Busbars .....	10
11. Self-Test Overview .....	11
12. Relay Functionality .....	12
13. Remote Monitoring .....	13
14. Technical Data .....	18
15. Ordering Information.....	18

# 1. Introduction

Despite all the safety built into our electrical rail systems, failures can and do occur. MRD's Earth Leakage Detectors (ELD's) significantly reduce the likelihood of failure or accidents due to leakage faults.

An Earth Leakage Detector (ELD) monitors electrical systems where the busbars (the conductors distributing power) are not directly connected to earth under normal conditions. Such a configuration is known as an IT system. The ELD is used to detect any unintended electrical leakage from these busbars to the earth, which could indicate insulation failures or other issues. The main purpose of the ELD is to ensure that there are no leakages of electrical current from the power system (busbars) to earth, except during controlled conditions such as testing. This helps in maintaining system safety and functionality.

## 2. General Description

### Leakage from battery

The interlocking circuits in railway signalling are often supplied from a battery in which neither of the poles are connected to earth. In the event of a single fault there is no danger, however, two or more faults occurring at the same time could create a dangerous situation. Therefore, it is vitally important to supervise the battery supply continuously to prevent this from happening.

### Leakage from cables, lamp circuits, etc.

Cables which run in parallel with AC electrified railways are subjected to induced voltages. If an earth leakage occurs in the cable, these voltages can disturb devices which are connected to both cables. When earth faults occur in both the supply and return wires yet another hazardous condition is created.

These faults are detected and indicated reliably with MRD's Earth Leakage Detector.

## 3. Product Features

- AC Supply or DC Supply versions.
- Auto detects & monitors AC or DC busbar voltages: 8 – 150V DC, 0 – 650V AC.
- Continuously displays fault level in K $\Omega$  – Remove leakages before critical level reached.
- Displays fault time – Helps track cause of fault.
- Adjustable sensitivity: 10 K $\Omega$  – 200 K $\Omega$ .
- Adjustable delay: 2 sec – 10 sec.
- Self-Test and Reset buttons.
- Power on and trip indications.
- Fail-safe or Non-Fail-safe trip contact operation.
- Compact Size - Din rail or Panel mounting.
- Remote reset.
- Remote interrogation via RS-485 Communications Link.

## 4. Wiring Diagram

**NOTE:**

The use of fuses on the ELD Supply and ELD Busbar is recommended for electrical safety for signalling circuits (1A or 2A fuse is recommended).

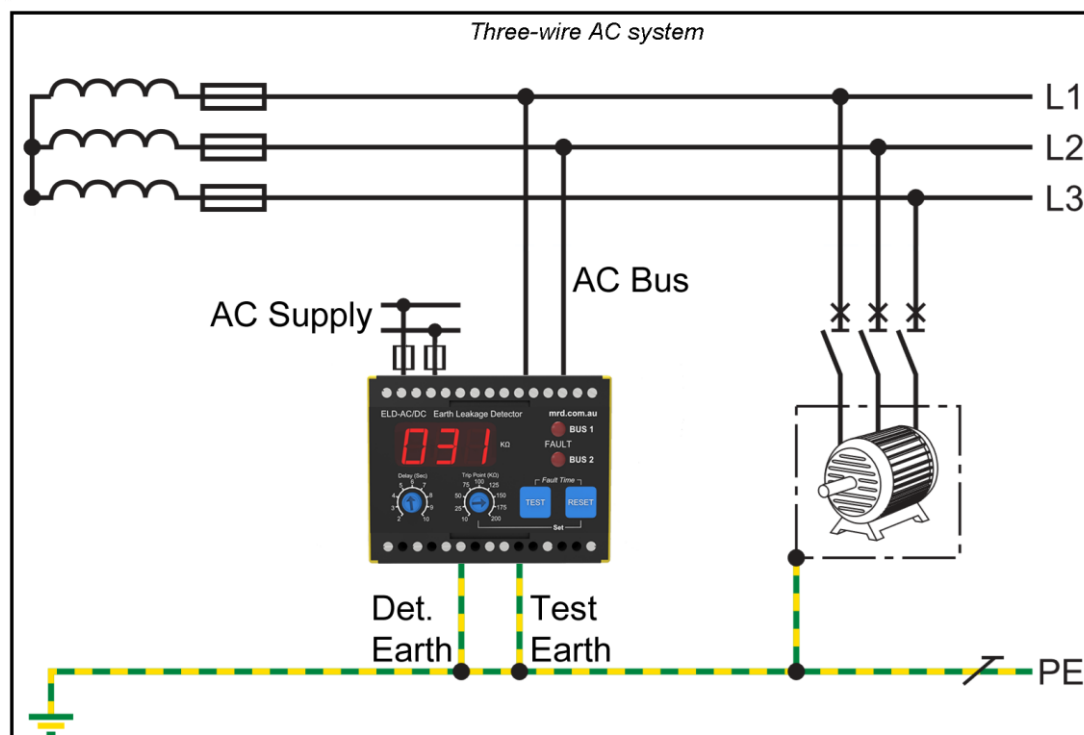
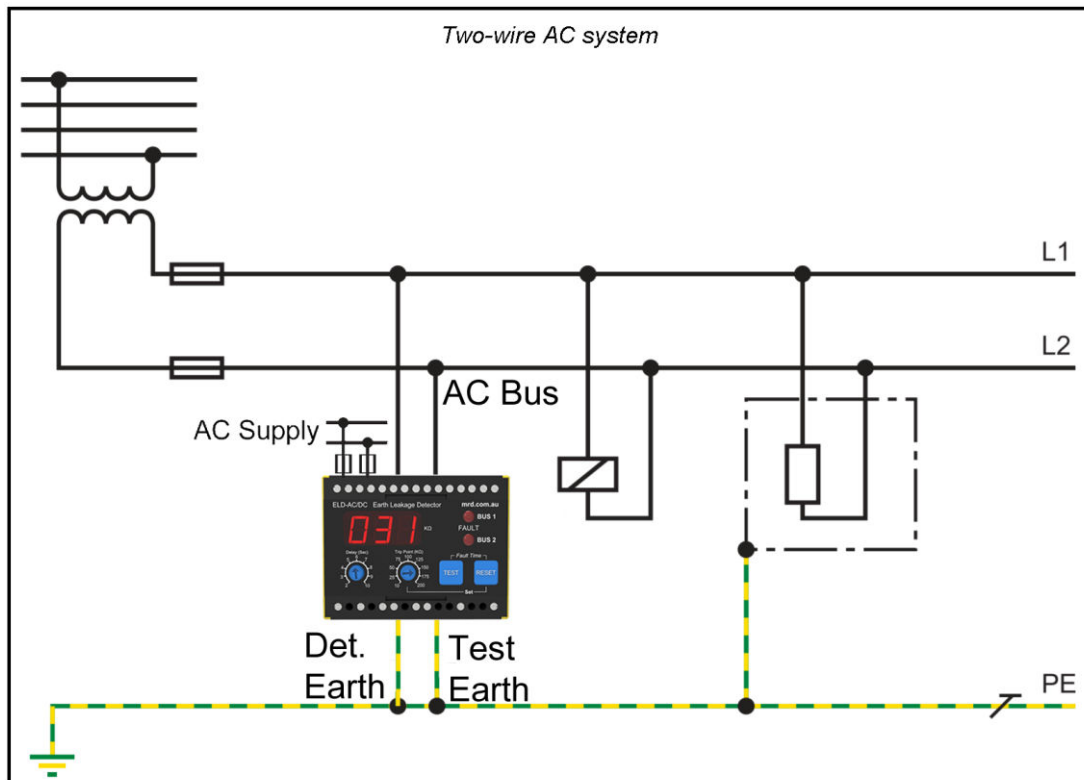

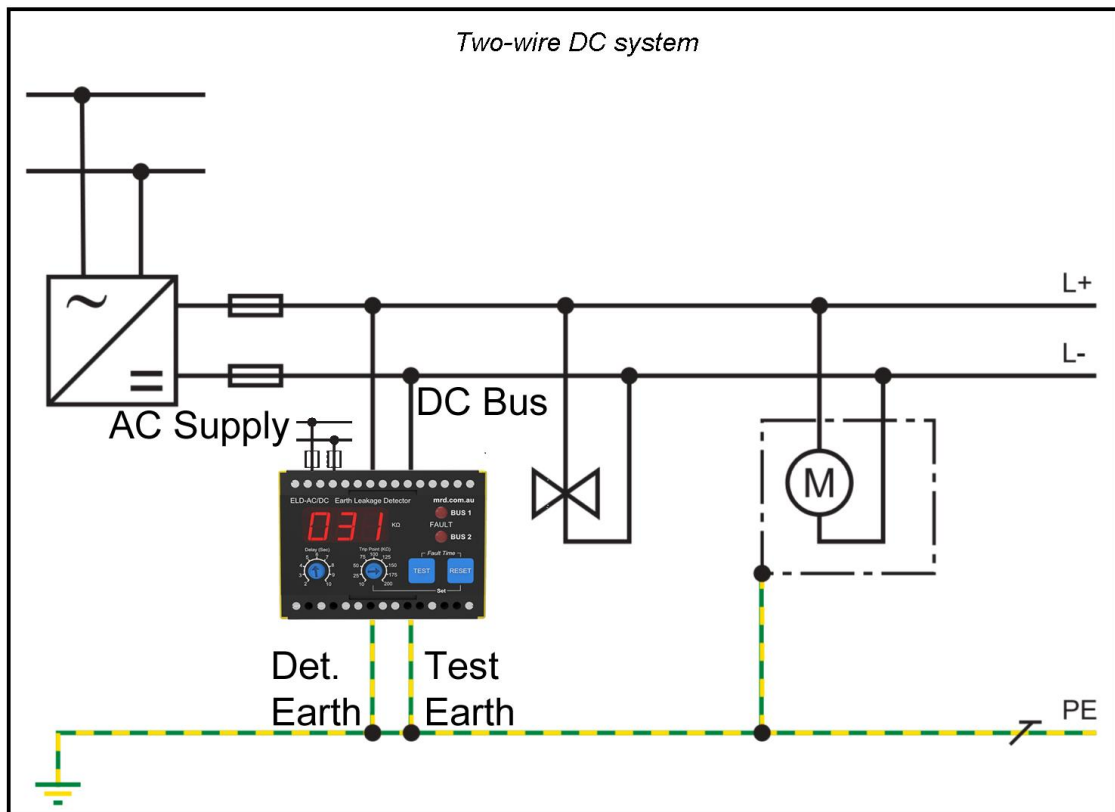
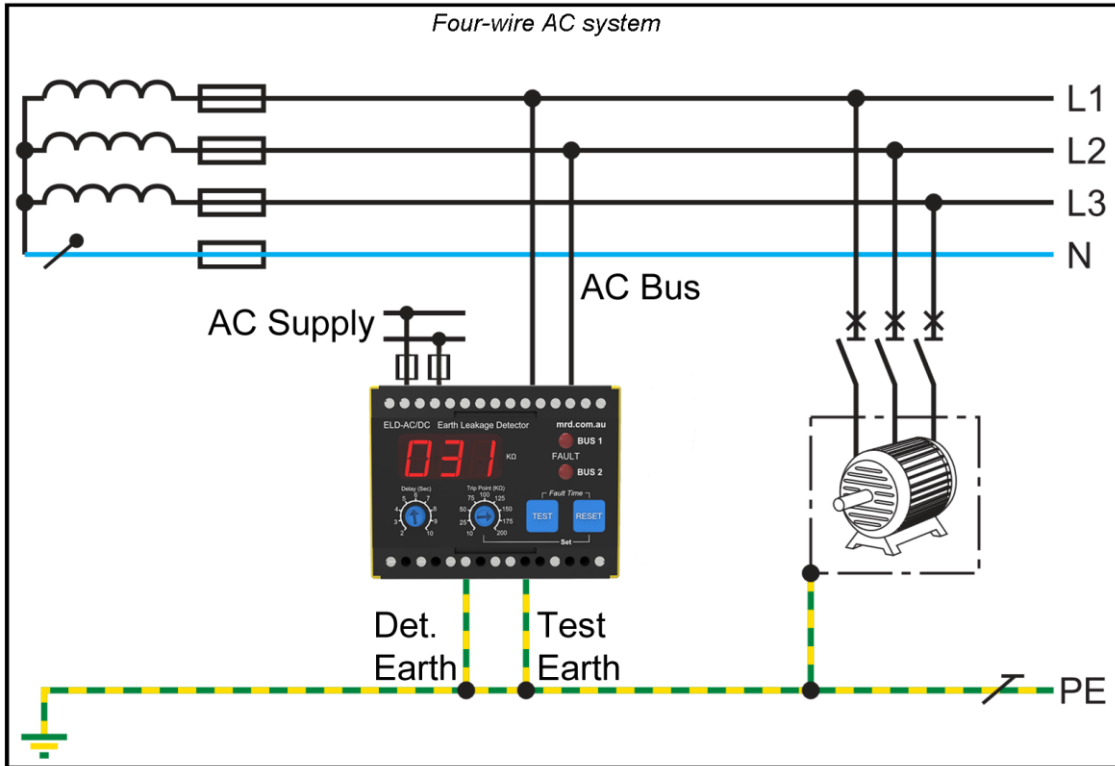

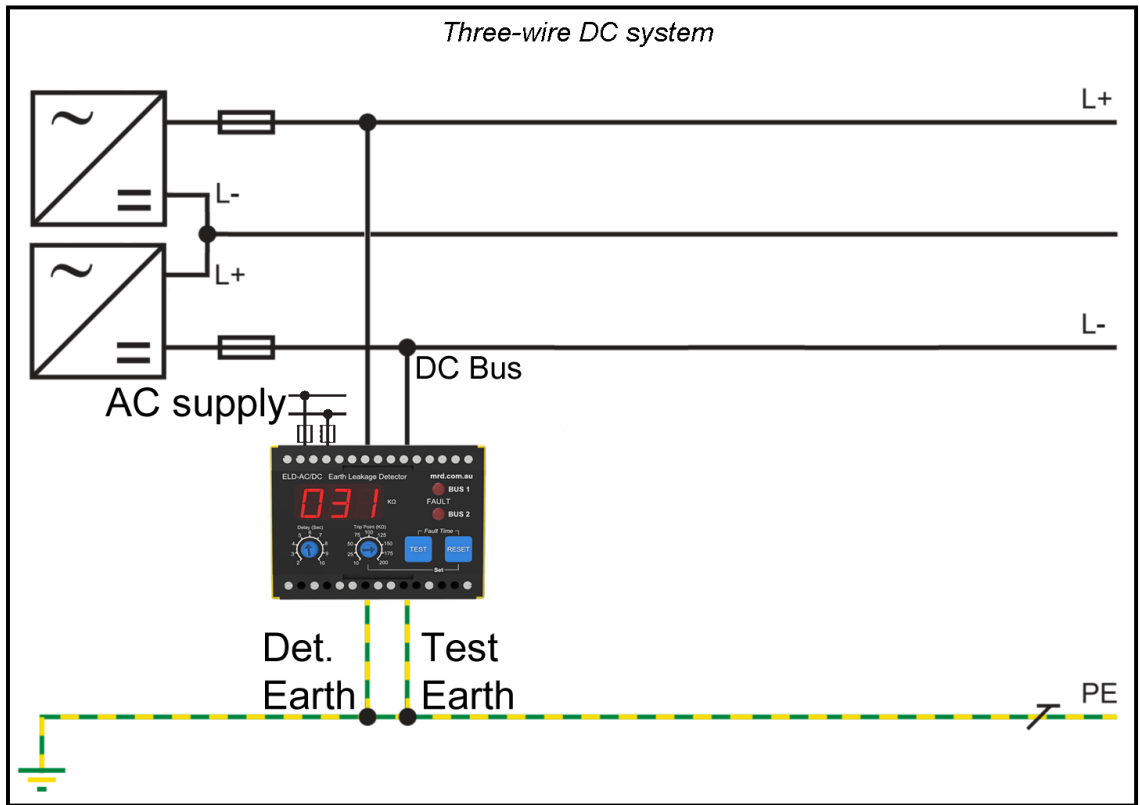



# 5. Connectors

No.	NAME	DESCRIPTION
<b>AC Version</b>		
# 1	110V AC	AC Supply voltage input 85-264V AC
# 3	110V AC	AC Supply voltage input 85-264V AC
<b>DC Version</b>		
# 1	12V-24V DC	+DC Supply voltage input 9-36V DC
# 3	12V-24V DC	-DC Supply voltage input 9-36V DC
# 5	Det. Earth	Main earth
# 6	Test Earth	Use for testing earth integrity. Link to 'Det.Earth' if not required
# 8	+ve DC BUS 1	Connect +ve to BUS 1 terminal when monitoring DC busbar *
# 9	-ve DC BUS 2	Connect -ve to BUS 2 terminal when monitoring DC busbar *
# 12	AC BUS 1	Connect to AC BUS 1 when monitoring AC busbar *
# 15	AC BUS 2	Connect to AC BUS 2 when monitoring AC busbar *
# 16	T1	Link T1 & T2 to enable internal 1K termination resistor for RS-485 comms if required
# 17	T2	Link T1 & T2 to enable internal 1K termination resistor for RS-485 comms if required
# 18	RXD	RS-485 comms.
# 19	TXD	RS-485 comms.
# 20	GND	Main earth. Internally connected to detector earth terminal # 5
# 21	Reset	Remote Reset. Momentarily link terminal #21 & #22 to clear fault
# 22	Reset	Remote Reset. Momentarily link terminal #21 & #22 to clear fault
# 23	Mode	Unlinked for fail-safe mode. Link terminal #23 & #24 for non-fail-safe mode
# 24	Mode	Fail-safe mode – De-energized on fault. Non fail-safe mode – Energized on fault
# 25	1 - Back	Back relay fault contacts
# 26	1 - Front	Front relay fault contacts
# 27	1 - Armature	Armature relay fault contacts
# 28	2 - Back	Back relay fault contacts
# 29	2 - Front	Front relay fault contacts
# 30	2 - Armature	Armature relay fault contacts

**NOTE:**

Only connect one busbar type, AC or DC as the unit monitors one or the other.

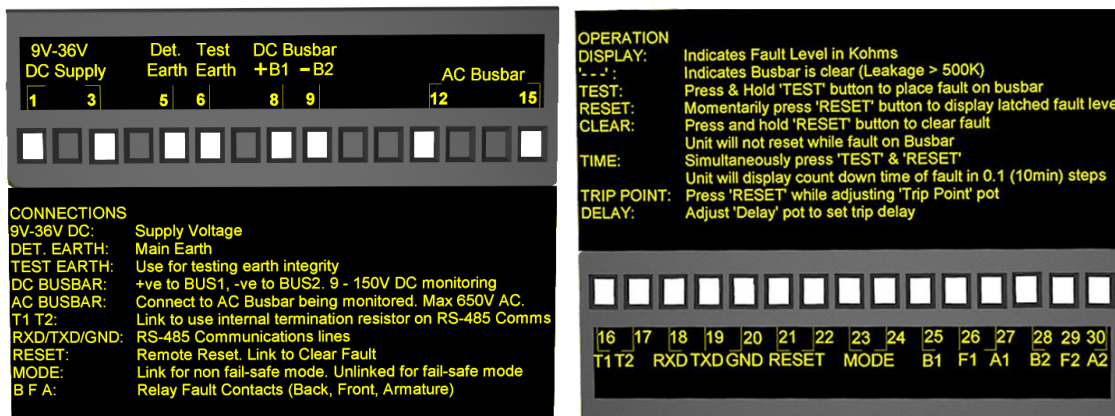

## 6. Installation

1. Mount detector on a din rail using the rail clip on base of unit.  
Alternatively, the unit can be panel mounted using the two base holes as a mounting point.  
An optional Q-Style panel mount bracket is also available (see section 7).
2. Make connections as shown in wiring diagrams.  
If monitoring AC busbar, wire as per AC diagram.  
If monitoring DC busbar, wire as per DC diagram.  
Note 1: Only monitors one busbar, AC or DC. Do not connect both.  
Note 2: Do not over loosen terminal screws as this may cause terminal holders to displace from terminal block.
3. Test Earth / Detector Earth Connections.  
Our recommendation is to use a separate earth stake for test earth and detector earth.  
Why? The separate test earth proves the detector earth connection when performing the self-test function (pressing the test button). This places an internal 10 K $\Omega$  resistor between the busbar and the test earth.  
The leakage return path is between the test earth stake and the detector earth stake via a body of earth.  
If there is a problem with the detector earth connection this will be indicated by self-test function failure.  
The self-test function should be performed routinely as specified by signaling authority.  
  
If the test earth and detector earth are connected together the unit will still function correctly, although pressing the self-test button will not check the validity of the detector earth. In fact the self-test will still work even if no connection to the main earth is made as long as a link is placed between the test and detector earths.  
This defeats the purpose of the self-test function.
4. Adjust 'Trip Point' and 'Trip Delay' pots on the front panel to desired thresholds.
5. The unit is now connected for operation.  
Please follow operation instructions to ensure correct use of unit.

## 7. Q-Style Panel Mount Bracket

An optional addition to the ELD is the Q-style Panel Mount Bracket (Part Number: ELDAC/DC-AUTO-PMB). The Panel Mount Bracket allows the ELD to be installed in existing Q-style racks.

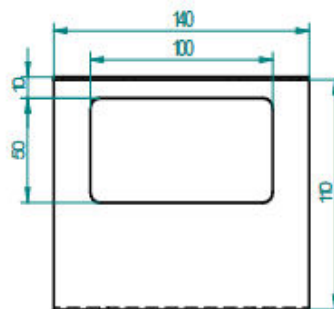
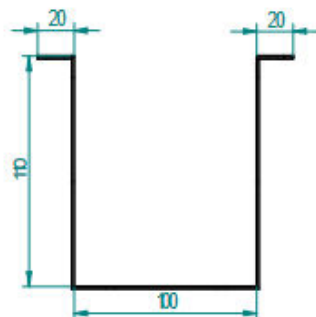
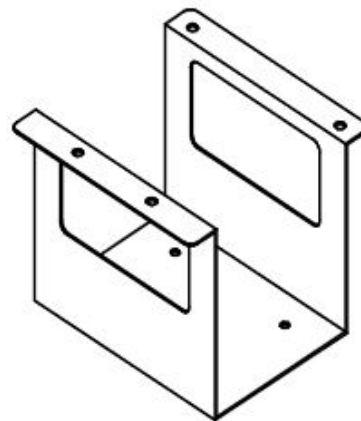
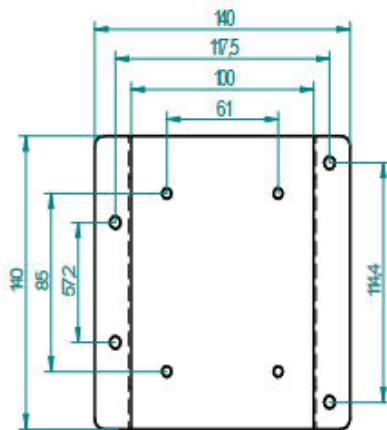

## 8. Functions

Display:	Indicates leakage level in K $\Omega$ .
'---':	Indicates busbar is clear & that the current leakage level is above 500 K $\Omega$ .
Test:	<p>Press &amp; hold test button to place 10 K<math>\Omega</math> fault on busbar. Once the set delay &amp; trip thresholds have been reached the unit will trip and latch a fault.</p> <p>This is indicated by the illumination of bus fault LED's. Displayed leakage level should also reach approximately 10 K<math>\Omega</math> while performing test. Existing leakages will affect displayed leakage value when performing this test.</p> <p><b>TEST NOTES:</b> Self-test will only operate correctly if low resistance connection between 'Test Earth' &amp; 'Detector Earth' terminals exist. This connection is usually made through test stakes in the ground. Failure of unit to trip when performing self-test indicates a problem with the test earth or detector earth connections or an existing fault. Link the 'Test Earth' &amp; 'Detector Earth' if not using test stakes or to prove unit. Pressing 'Test' for more than ten seconds at a time will cause unit to remove Test resistor from busbar to prevent over heating or damage to unit.</p>
Reset:	<p>Momentarily press 'RESET' to display stored fault level. Press &amp; hold reset in to clear fault. Unit will not reset while fault remains on busbar. If power is interrupted to unit, latched faults will be restored as stored in memory, however, fault time will be lost &amp; displayed as '00.0'.</p>
Fault Time:	<p>Simultaneously press 'TEST' &amp; 'RESET'. Unit will display count down time of fault in 0.1 (10 min) steps. Display will show '00.0' until first ten minutes has lapsed. Eg.1. '00.1' indicates fault occurred at minus 10 minutes. Eg.2. '11.1' indicates fault occurred at minus 11 hours and ten minutes. If power is interrupted to unit, latched faults will be restored as stored in memory, however, fault time will be lost &amp; displayed as '00.0'.</p>
Trip Point:	<p>Press 'RESET' while adjusting 'Trip Point' pot. Display will show trip point setting. Trip point will not be displayed if there is a latched fault on busbar.</p>
Delay:	Adjust 'Delay' pot to set trip delay.

## 9. Operation instructions for monitoring AC busbars

### Step 1 – Initial Power Up

When the unit is initially powered up it detects the busbar voltage being monitored. The unit will display 'CAL' during this procedure. Following detection of the AC busbar the unit will display 'AC' for 2 seconds.

#### NOTE:

It is not necessary for the AC busbar being monitored to be powered up for the AC busbar to be detected. It is only necessary for the unit to have a connection through the secondary winding of the AC busbar supply transformer being monitored. This is because the unit injects a DC voltage into one leg of the AC busbar and looks for a return voltage on the other leg.

If the AC busbar is not connected the unit will trip indicating a fault condition which can only be reset once this connection is present.

A power down condition on the AC busbar will not cause the unit to trip as long as this connection is made.

### Step 2 – Trip Point & Trip Delay Adjust

Adjust 'Trip Point' and 'Trip Delay' pots on the front panel to desired thresholds.

For fine trip point adjustment, press and hold the 'Reset' button while adjusting the 'Trip Point' pot.

The Display will show the set 'Trip Point' while the 'Reset' button is pressed unless there is a fault latched.

If there is a fault latched the display will show the level at which the trip occurred.

### Step 3 – Display Interpretation

The unit displays the current leakage level on the 3 digit 7-segment display in K $\Omega$ .

When there is no leakage or the leakage is above 500 K $\Omega$  the unit displays '- - -'.

Display other than '- - -' indicates an existing earth leakage.

Both BUS 1 and BUS 2 Fault LEDs indicate a latched fault when continually illuminated.

Distinguished LEDs indicate the Busbar is clear.

### Step 4 – Self Test

The unit has a built-in test facility which momentarily connects a 10 K $\Omega$  resistor between the busbar and test earth.

Press & hold the 'TEST' button to place a 10 K $\Omega$  fault on the busbar.

Once the set delay and trip thresholds have been reached the unit will trip and latch the fault.

This is indicated by the illumination of BUS1 and BUS2 fault LED's and the trip relay contacts changing state.

Displayed leakage level should also reach approximately 10 K $\Omega$  while performing test.

Press and hold 'Reset' button to clear fault.

#### NOTE:

Self-test function will only work when there is no existing latched fault.

For this feature to operate correctly, a low resistance connection between the 'Test Earth' and 'Detector Earth' terminals must exist.

This is usually made via test stakes in ground.

Failure of unit to trip when performing self-test indicates a likely problem with test earth or detector earth connections or an already latched fault.

Link the 'Test Earth' & 'Detector Earth' if not using test stakes or to prove unit.

Pressing 'Test' for more than ten seconds at a time will cause unit to remove test resistor from busbar to prevent over heating or damage to unit.

### Step 5 – Fault Reset

When a leakage occurs that exceeds the set trip point and delay time, a fault is latched.

Both fault LED's illuminate and the trip relay contacts change state.

Momentarily pressing the reset button will display the recorded trip level for 1 second without resetting the fault.

Press and hold the reset button to reset a latched fault.

Resetting the fault will cause both fault LEDs to extinguish and the trip relay contacts to change state.

#### NOTE:

A latched fault can only be reset once the fault has been removed from the busbar.

## 10. Operation instructions for monitoring DC busbars

### Step 1 – Initial Power Up

When the unit is initially powered up it detects the busbar voltage being monitored.

The unit will display 'CAL' during this procedure.

Following detection of the DC busbar the unit will display the detected DC voltage for 2 seconds followed by 'DC' for 2 seconds.

#### NOTE:

If the DC busbar is not present the unit will trip indicating a fault condition.

This fault condition will automatically reset once the DC busbar is present.

### Step 2 – Trip Point & Trip Delay Adjust

Adjust 'Trip Point' and 'Trip Delay' pots on the front panel to desired thresholds.

For fine trip point adjustment, press and hold the 'Reset' button while adjusting the 'Trip Point' pot.

The Display will show the set "Trip Point" while the 'Reset' button is pressed unless there is a fault latched.

If there is a fault latched the display will show the level at which the trip occurred.

### Step 3 – Display Interpretation

The unit displays the current leakage level on the 3 digit 7-segment display in K $\Omega$ .

When there is no leakage or the leakage is above 500 K $\Omega$  the unit displays '- - -'.

Display other than '- - -' indicates an existing earth leakage.

The BUS 1 Fault LED indicates a latched fault on BUS 1 when continually illuminated.

The BUS 2 Fault LED indicates a latched fault on BUS 2 when continually illuminated.

Distinguished LEDs indicate the Busbar is clear.

### Step 4 – Self Test

The unit has a built in test facility which momentarily connects a 10 K $\Omega$  resistor between the busbar and test earth.

Press & hold the 'TEST' button to place a 10 K $\Omega$  fault on the busbar.

Once the set delay and trip thresholds have been reached the unit will trip and latch the fault.

This is indicated by the illumination of BUS1 or BUS2 fault LED's and the trip relay contacts changing state.

Displayed leakage level should also reach approximately 10 K $\Omega$  while performing test.

Press and hold 'Reset' button to clear fault.

Repeat this process for the alternate DC busbar.

#### NOTE:

Self-test function will only work when there is no existing latched fault.

For this feature to operate correctly, a low resistance connection between the 'Test Earth' and 'Detector Earth' terminals must exist.

This is usually made via test stakes in ground.

Failure of unit to trip when performing self-test indicates a likely problem with test earth or detector earth connections or an already latched fault.

Link the 'Test Earth' & 'Detector Earth' if not using test stakes or to prove unit.

Pressing 'Test' for more than ten seconds at a time will cause unit to remove test resistor from busbar to prevent over heating or damage to unit.

### Step 5 – Fault Reset

When a leakage occurs that exceeds the set trip point and delay time, a fault is latched.

BUS 1 and/or BUS 2 LED's illuminate indicating which busbar the fault is on and the trip relay contacts change state.

Momentarily pressing the reset button will display the recorded trip level for 1 second without resetting the fault.

Press and hold the reset button to reset a latched fault.

Resetting the fault will cause the Busbar fault LEDs to extinguish and the trip relay contacts to change state.

#### NOTE:

A latched fault can only be reset once the fault has been removed from the busbar.

# 11. Self-Test Overview

## ELD Self-Test Function

The ELD includes a 'Test' button which, when activated, simulates an earth leakage. This is achieved by connecting a 10K Ohm resistor between one of the busbar nodes and the ELD's earth terminal, which itself is connected to the system's ground. This setup tests the ELD's ability to detect an electrical path to earth and also verifies that the earthing system is effectively connected.

## How the Test Works

**Normal Condition:** When the test button is pressed, if the ELD and the earthing system are functioning correctly, the ELD will detect the resistance of exactly 10K Ohm (plus or minus 1K to account for minor variations). This will be displayed as "10K +/- 1K" on the ELD's display.

**Open Circuit:** If the ELD displays '- - -', it indicates that there is no continuity in the earthing connection — essentially, an open circuit. This suggests that the wiring or connections in the earthing system might be disconnected or damaged.

**High Resistance:** If the display shows a resistance greater than 11K, it indicates that there is additional resistance somewhere in the earthing system. This could be due to corroded or loose connections, or inadequate grounding, and means the total resistance is the sum of the intentional 10K from the test resistor and the unintended additional resistance.

## Conclusion from Testing

The test function of the ELD helps confirm:

- The ELD's capability to detect a controlled leakage (simulated by the test resistor).
- The integrity and effectiveness of the earthing system's connections and wiring.

By regularly testing with the ELD's test function, maintenance teams can ensure the safety and functionality of the railway's electrical infrastructure, addressing any issues indicated by the test results immediately.

This simple testing method is a proactive step in preventing potential system failures or safety hazards due to earthing issues in railway applications.

To ensure the self-test functions correctly, MRD recommends a test earth stake resistance of less than 50 ohms.

# 12. Relay Functionality

## Relay Functionality

The relay contacts of the ELD are listed in the table below.

Contact	Contact Function	Description
# 25	1 - Back	Back relay fault contacts
# 26	1 - Front	Front relay fault contacts
# 27	1 - Armature	Armature relay fault contacts
# 28	2 - Back	Back relay fault contacts
# 29	2 - Front	Front relay fault contacts
# 30	2 - Armature	Armature relay fault contacts

Both sets of relay contacts function identically for both AC and DC busbars. When the unit is not powered, the Armature and Back contacts are connected.

When the unit is powered, and there is not fault on the busbar, the armature and front contacts are connected.

When the unit is powered, and there is a fault applied, the armature and back contacts are connected.

The above can be reversed when the MODE connections are shorted together. These can be seen in the table below.

Contact	Contact Function	Description
# 23	Mode	Unlinked for fail-safe mode. Link terminal #23 & #24 for non-fail-safe mode
# 24	Mode	Fail-safe mode – De-energized on fault. Non fail-safe mode – Energized on fault



# 13. Remote Monitoring

## INTRODUCING THE ELD PROTOCOL

RS485 or EIA (Electronic Industries Association) RS485 is a balanced line, half-duplex transmission system allowing transmission distances of up to 1.2 km. The following table summarises the RS-485 Standard:

PARAMETER	
Mode of Operation	Differential
Number of Drivers and Receivers	32 Receivers
Maximum cable length (metres)	1200
Data rate (baud)	9600
Drive Load (Ohms)	120

Further information relating to RS485 may be obtained from either the EIA or the various RS485 device manufacturers:

- Texas Instruments
- Maxim Semiconductors

### Connecting the ELD's

Screened twisted pair cable should be used. All "TX" connections should be connected together using one conductor of the twisted pair cable all "RX" connections should be connected together using the other conductor in the pair. The cable screen should be connected to the "GND" terminal.

A twisted pair cable with a characteristic impedance of 100/120 ohms is recommended, the cable should be terminated using the internal termination resistor.

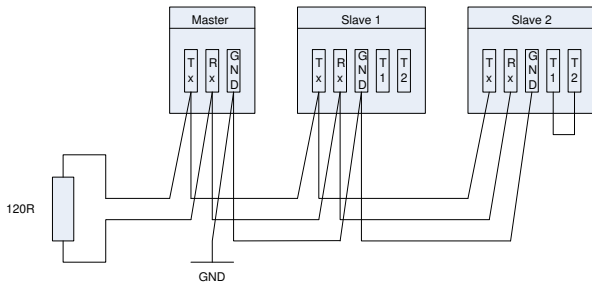

There must be no more than two wires connected to each terminal, this ensures that a "Daisy Chain" or "straight line" configuration is used. A "Star" or a network with "Stubs (Tees)" is not recommended as reflections within the cable may result in data corruption.

Daisy Chained Connection (Correct)

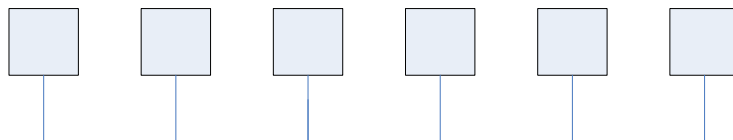

## ELD Messages

Communication on an ELD Network is initiated (started) by a “Master” with a “query” to a “Slave”. The “Slave” which is constantly monitoring the network for “Queries” will recognize only the “Queries” addressed to it and will respond either by performing an action (setting a value for example) or by returning a “response”. Only the Master can initiate a query.

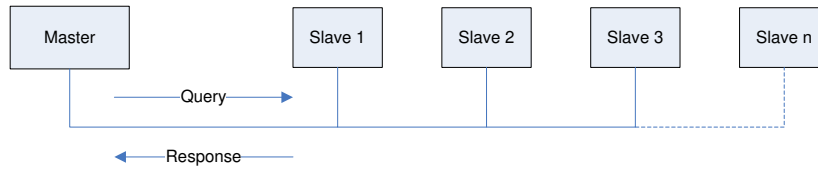

In the ELD protocol the master can address individual slaves, or, using a special “Broadcast” address, can initiate a broadcast message to all slaves.

## ELD ID

The ELD uses an ID to identify individual units. The ELD defaults to an ID of 1. If multiple units are used in the same circuit, each unit will need a unique ID. This can be changed by following this procedure:

- 1) Power off the ELD
- 2) Press both Test and Reset buttons and power up the ELD
- 3) Once booted, without releasing Reset button, toggle the Test button to change its ID.

## ELD Message Format

The ELD protocol defines the format for the master’s query and the slave’s response.

The query contains the device (or broadcast) address, a function code defining the requested action, any data to be sent, and an error-checking field.

The response contains fields confirming the action taken, any data to be returned, and an error-checking field. If an error occurred in receipt of the message, or if the slave is unable to perform the requested action, the slave will construct an error message and send it as its response.

## Query

The example illustrates a request for software version.

	Start of heading	ID		Command			Checksum	End of text	End of transmission
Hex	0x01	0x30	0x31	0x53	0x57	0x3F	0x4B	0x03	0x04
ASCII	\01	0	1	S	W	?	K	\03	\04

## Response

	Start of heading	ID		Command			Checksum	End of text	End of transmission	
Hex	0x01	0x30	0x30	0x56	0x32	0x2E	0x30	0x47	0x03	0x04
ASCII	\01	0	0	V	2	.	0	G	\03	\04

Master Address - 00  
 Broadcast Address - 99  
 ID (default 1) - 1 to 98

Obs.: When broadcast id is used there is no response from ELD’s, but the command is executed.

## Checksum

The ELD protocol uses an error checking process, the checksum sums up all the values from Start of heading to the end of command then the lower byte is sent, calculated and compared to the command received.

Example: Software version command

$0x01 + 0x30 + 0x30 + 0x56 + 0x32 + 0x2E + 0x30 = 0x147$

$0x147 = 00000001\ 01000111$

High byte =  $00000001 = 0x01$

Lower byte =  $01000111 = 0x47$

## ELD Commands

### ID query:

Command – D

Response – Actual ID number

This command sends back the ID number.

### Edit ID:

Command – EDID + “New ID” (Note: there is a space character between the command and the new ID)

Response – ACK (\06)

This command changes the default ID (1) number for a new ID.

Example: EDID 2 - Set the ID number to 2.

### Trip Point:

Command – TP

Response – 10 to 100 (Kohm)

This command sends back the trip point level.

### Bus Mode:

Command – BM

Response – 0 or 1

This command sends back the ELD operation mode AC (1) or DC (0).

### Bus Leakage Status:

Command – BL

Response – 0, 1 or 2

This command sends back in which bus is the current fault.

AC Mode: 0 - No Fault or 1 – Fault

DC Mode: 0 – No Fault, 1 – Bus1 Fault, 2 – Bus2 Fault

### Time Delay:

Command – TD

Response – 2 to 10 (seconds)

This command sends back the time delay level.

### DC Fault Time Bus1:

Command – DCFT1

Response – (minutes)

This command sends back the value in minutes when the fault occurred on Bus1. If the unit has been powered down this value becomes 0 (not recorded).

### DC Fault Time Bus2:

Command – DCFT2

Response – (minutes)

This command sends back the value in minutes when the fault occurred on Bus2. If the unit has been powered down this value becomes 0 (not recorded).

### **AC Fault Time:**

Command – ACFL

Response – (minutes)

This command sends back the value in minutes when the fault occurred on AC-Bus. If the unit has been powered down this value becomes 0 (not recorded).

### **DC Fault Level Bus1:**

Command – DCFL1

Response – 0 to 200(Kohm)

This command sends back the value of the fault level occurred on Bus1. If 201 there is no fault.

### **DC Fault Level Bus2:**

Command – DCFL2

Response – 0 to 200(Kohm)

This command sends back the value of the fault level occurred on Bus2. If 201 there is no fault.

### **AC Fault Level:**

Command – ACFL

Response – 0 to 200(Kohm)

This command sends back the value of the fault level occurred on AC-Bus. If 201 there is no fault.

### **DC Voltage:**

Command – V

Response – (volts)

This command sends back the value in volts of the DC Bus (0 when in AC Mode).

### **Resistor Leakage:**

Command – RLE

Response – 0 to 500(Kohm)

This command sends back the value of the actual resistor leakage. If 1000 it is open circuit.

### **Self-test Leakage:**

Command – TEST

Response – ACK (\06)

This command sets a 10Kohm resistor between a bus and GND. When in DC mode the resistor cycle between Bus 1 and 2.

### **Reset Trip Fault:**

Command – RSTF

Response – ACK (\06)

This command resets the trip fault recorded in the EEPROM.

### **Reset Hardware:**

Command – RESET

Response – ACK (\06)  
This command resets the ELD hardware.

### **Software Version:**

Command – SW?  
Response – current software version  
This command sends back the software version.

## 14. Technical Data

### AC Supply Voltage (AC Version)

Supply Voltage	85 – 264V AC
Frequency Range	50 – 60 Hz
Max. Power consumption	3VA

### DC Supply Voltage (DC Version)

Supply Voltage	9 – 36V DC
Max. Power consumption	3W

### Monitoring Voltage Range

DC Busbar Voltage	8 – 150V DC
AC Busbar Voltage	0 – 650V AC

### Dimensions

Height	75mm
Depth	110mm
Width	100mm

### Environmental Conditions

Operating Temperature	-10deg.C to +60deg.C
Storage Temperature	-10deg.C to +80deg.C
Climate class according to IEC 721	3K5 without condensation

### General Data

BUS/GND Isolation Resistance	>100 K $\Omega$
Connection Type	4mm Screw Terminal
Rapid Mounting	DIN #3 rail EN50022
Screw mounting	Screw mounts
Panel mounting	Panel mounting bracket available
Protection Class	
- Internal components	IP30
- Terminals	IP02
- Housing	X470b, Self-extinguishing polycarbonate
- Shipping Weight	0.4 Kg
Fault Contact Ratings	0.6A 125V AC 0.6A 110V DC 2.0A 30V DC
Trip Delay Range	Adjustable 2 sec – 10 sec
Trip point	Adjustable 10 K $\Omega$ – 200 K $\Omega$

## 15. Ordering Information

### Part Number

ELDAC/DC-AUTO-110  
(AC Version)  
ELDAC/DC-AUTO-12  
(DC Version)  
ELDAC/DC-AUTO-PMB

### Description

Monitors AC or DC busbars - Auto Detecting  
Monitors AC or DC busbars - Auto Detecting  
Q-Style Panel Mount Bracket