

AWS1-LP

Automatic Warning System Low Profile Electro Inductor



Version	Author	Description	Date
1.1	Callum Gersbach	Draft	18/03/2013
1.2	Callum Gersbach	Preliminary	10/07/2013
1.3	Callum Gersbach	Update	23/9/2013
1.4	Callum Gersbach	Update	3/9/2014
1.5	Callum Gersbach	Update	4/9/2014
1.6	Callum Gersbach	Update	17/10/2014
1.7	Callum Gersbach	Update	3/3/2015
1.8	Liam Hoffman	Updated warranty details	04/02/2025

Index

Index	II
1 General Information.....	1
1.1 Introduction.....	1
1.2 Part Numbers	1
1.3 Contact Information	1
1.4 Disclaimer	1
2 Features and Benefits.....	2
2.1 Features.....	2
2.2 Warranty.....	2
2.3 Safety.....	2
2.4 Compliance	2
2.5 Documentation.....	2
3 Technical Specifications.....	3
3.1 General Description of Operation	3
3.2 Operating Values	3
3.3 Magnetic Flux Densities.....	3
4 Physical Characteristics	5
4.1 Dimensions	5
5 Material Specification.....	6
5.1 Enclosure	6
5.2 Vibration mounts.....	6
5.3 Connector	6
5.4 Magnets.....	6
5.5 Coils	6
6 Testing, Maintenance and Approval	7
6.1 Testing	7
6.2 Maintenance.....	7
6.3 Approval	7

1 General Information

1.1 Introduction

AWS are provided primarily to aid drivers in observing the fixed signals, particularly under adverse weather conditions, and is supplementary to the fixed signals, which the driver must observe. Although supplementary, its correct operation is of the highest importance since any conflict between the fixed signal and the AWS indications will confuse drivers.

The AWS1 is an Electro Inductor which, when energised, has it's South Pole Uppermost and this South Pole, following the North Pole of the permanent inductor, gives a "clear" indication to the driver.

On bi-directional lines, special permanent inductors called Suppressor Inductors (AWS2) may be used to prevent a train receiving AWS indications which were intended for trains going the opposite direction. These Inductors have a permanent inductor and, in addition, a supressing coil which, when energised, diverts the magnetic flux, supressing any indication to the train. This suppression is in accordance with section b8.31 of the group standards GE/RT8035.

1.2 Part Numbers

Part numbers for AWS-LP units are as follows.

Part Number	Description of Unit
AWS1-LP	Low Profile Electro Inductor
AWS2-LP	Low Profile Suppressor Inductor
AWS3	Permanent Magnet

1.3 Contact Information

MRD Rail Technologies Pty Ltd
 235 South Street
 Cleveland Qld 4163
 Phone: (07) 3821 5151
 E-mail: sales@mrd.com.au

1.4 Disclaimer

In issuing this document MRD makes no warranties, expressed or implied, that the compliance with all or any of the documents provided is sufficient on its own to ensure a safe system of work operation. Each user is reminded of its own responsibilities to ensure OH&S at work and its individual duties under the OH&S legislation.

2 Features and Benefits

2.1 Features

- 1) Low profile design suitable for installation on Slab Track or Sleepers
- 2) High strength enclosure machined from solid aluminium block
- 3) Watertight - Internals encapsulated in 3M re-enterable gel
- 4) Powder coated
- 5) Corrosion protected
- 6) Australia made
- 7) Local support
- 8) Low maintenance costs
- 9) 12-month Warranty

2.2 Warranty

The AWS unit is assured to live up to quality standards with a 10+ year life expectancy, backed up with a 12-month warranty. The unit is incredibly reliable, based on our standard AWS units manufactured since 1995.

Any damage incurred during transport or due to incorrect storage or incorrect installation is not covered by this warranty and will be repaired at a quoted price after inspection.

2.3 Safety

The AWS unit is designed to be as safe as possible. This is backed up by the fact that with over 1800 standard AWS units supplied to date since 1995 not a single safety incident has been reported.

2.4 Compliance

The AWS-LP is designed to conform to all applicable and relevant standards. The unit conforms to ISO9001, AS3100-1990 and AS1874.

2.5 Documentation

Documentation provided includes a User Manual, Technical Specifications Manual, Warranty, and Maintenance Manual.

3 Technical Specifications

3.1 General Description of Operation

The equipment in the track consists of a protective ramp preceding a Permanent Magnet (AWS3) and an Electro Inductor (AWS1). The Permanent Magnet has a North Pole uppermost and this magnetic field by itself gives a “caution” indication to the driver. The Electro Inductor (AWS1), when energised, has its South Pole uppermost and this South Pole, following the North Pole of the Permanent Magnet, gives a “Clear” indication to the driver. The layout of the AWS units on a one-directional line is shown below.

Figure 1

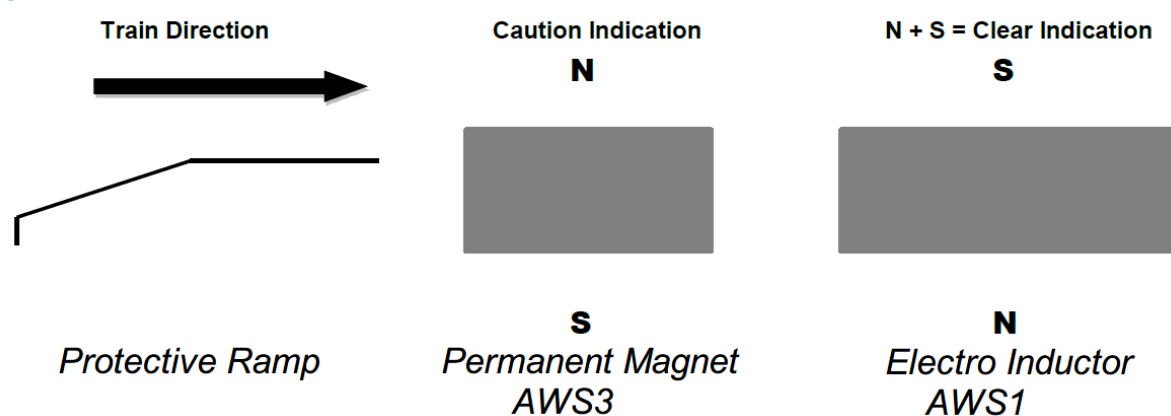

3.2 Operating Values

Nominal Coil Resistance	27 ohms \pm 5% @ 26° C
Nominal DC Current	900mA
Minimum Volts	22V DC @ 26°C
Nominal Volts	24V DC
Maximum Volts	28V DC

3.3 Magnetic Flux Densities

All AWS1-LP units are tested to be in compliance with section b9.1 of Group Standards GE/RT8035.

Magnet Type	Maximum Flux Density (mT)	Minimum Flux Density (mT)	Distance in Dimension A in figure 2	Distance in Dimension B in figure 2	Distance in Dimension C in figure 2
Electro Magnet (AWS1-LP)	18mT (energised) 0.7mT (de-energised)	3.5mT (energised)	150mm	115mm	100mm

Figure 2 – Planes of measurement as specified in Figure 5 of Group Standards GE/RT8035.

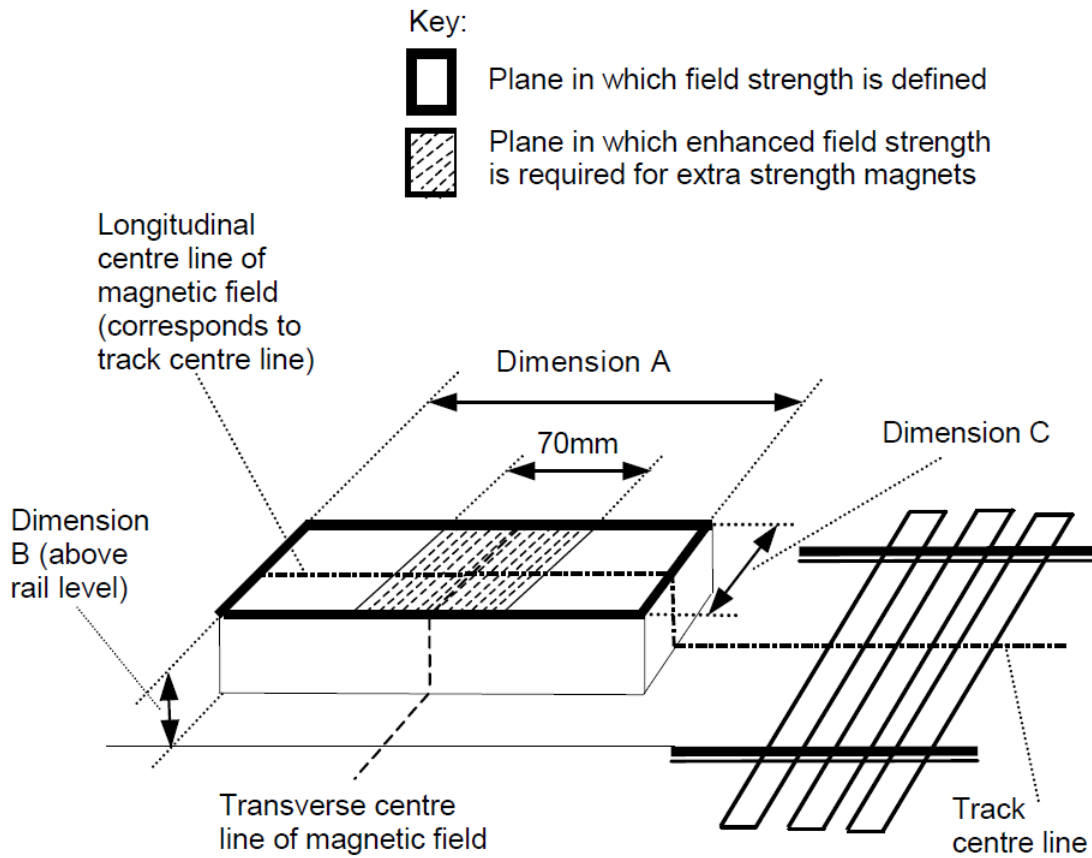

4 Physical Characteristics

4.1 Dimensions

The unit is 445mm x 795mm x 132mm. The unit is 43kg meaning that correct safety precautions must be taken into account when lifting it. The dimensions are illustrated below, from a top and side view.

Figure 3 – Dimensions of the AWS 1 – LP.

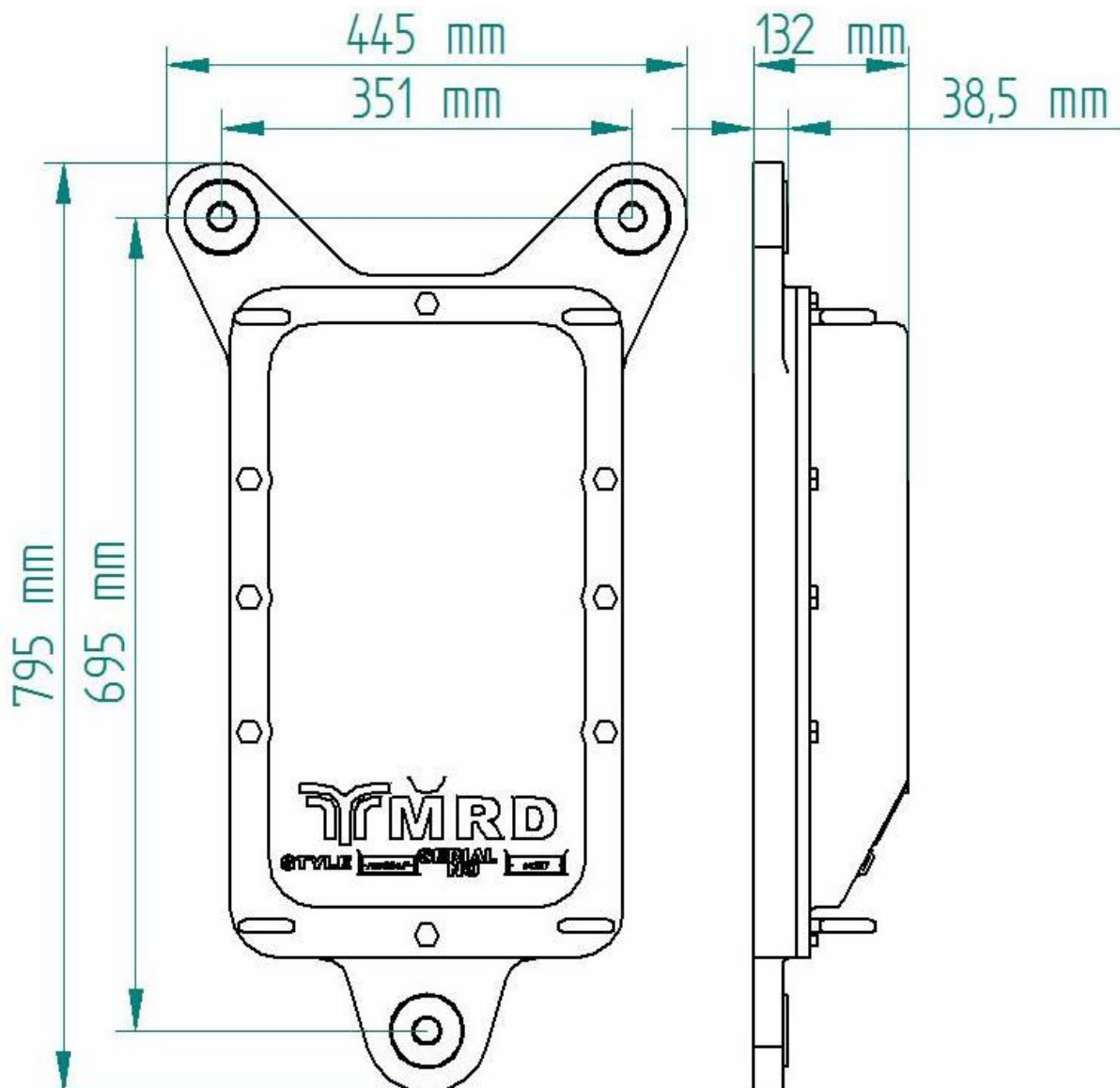

5 Material Specification

5.1 Enclosure

The lid and base enclosure are machined from a solid aluminium block Grade AA601. The enclosure is powder coated safety yellow.

5.2 Vibration mounts

The vibration mounts are manufactured from Vibrathane B-602. They are designed to be in accordance with EN61373, referred to in section b15.3.3 of the group standards GE/RT8035.

5.3 Connector

The AWS1-LP is fitted with an 8 metre long, 2.5mm square heavy duty cable with conduit.

5.4 Magnets

There are no magnets in the AWS-1 LP.

5.5 Coil

The coil is made from copper wire wound on Bakelite formers. Coils are impregnated with lacquer to prevent vibration or moisture damage.

6 Testing, Maintenance and Approval

6.1 Testing

The units are tested and comply with AS3100 – 1990 Approval and Test Specification – General requirements for electrical equipment.

Although, like all electrical equipment, the AWS system is not 100% failsafe in operation and is supplementary, its correct operation is of the highest importance as any conflict between the fixed signals and the AWS indications will cause confusion. For this reason, every effort is made during the manufacture and testing of the AWS units to ensure that the end product is of the highest possible quality.

It is this kind of quality assurance which MRD upholds with great pride which allows over 500 of our AWS1 units to have been supplied to date since 1995 with no failures or safety incidents.

6.2 Maintenance

Maintenance of the track equipment is minimal and consists of checking that all fixtures are tight, observing that the inductor cases are undamaged and checking that the cable connection on the unit is secure. Also, regular tests of magnetic field strength must be carried out using a special instrument called a Strength and Polarity Indicator.

Also, regular tests of magnetic field strength must be carried out using a special instrument called a Strength and Polarity Indicator.

6.3 Approval

The standard AWS units are currently approved and used by Queensland Rail and SA Public Transport Services.

The Low Profile (LP) variant of this product has not been approved and requires Type Approval.